

PARTICULARS:

- KEEL TO TOP OF HT 8' - 11"
- WATER LINE TO TOP OF HT 7' - 9"
- KEEL TO BOW EYE 2' - 6"
- STERN TO AFT END OF KEEL 1' - 9"
- STERN TO C.G. 9' - 9"
- TRANSOM TO C.G. 1' - 2"

PLAN VIEW

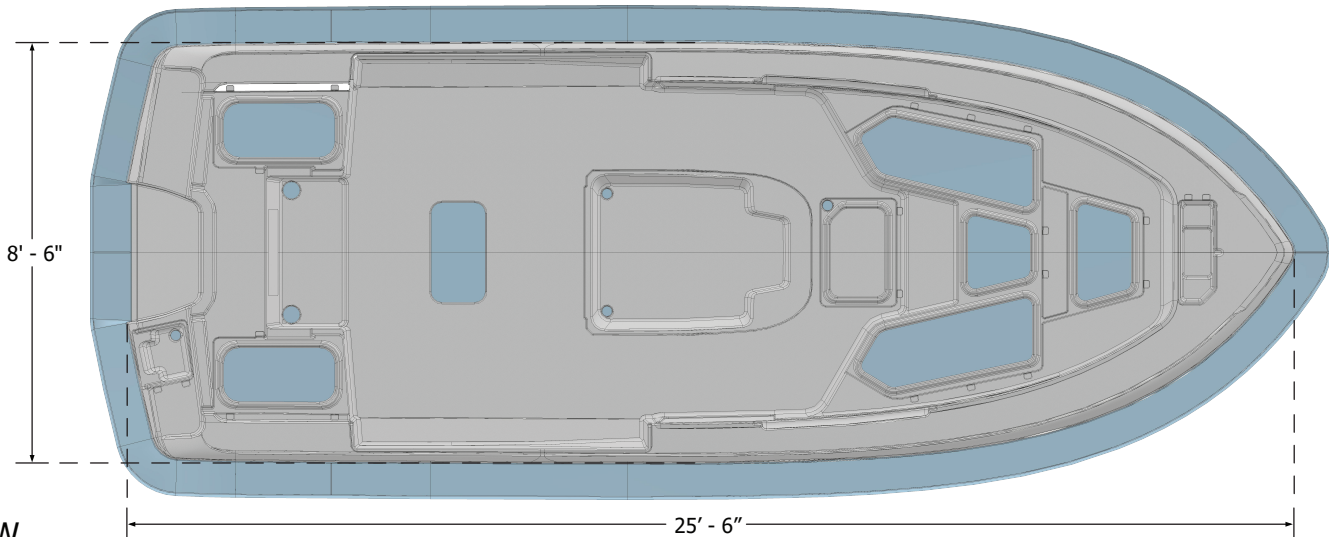

TRANSOM VIEW

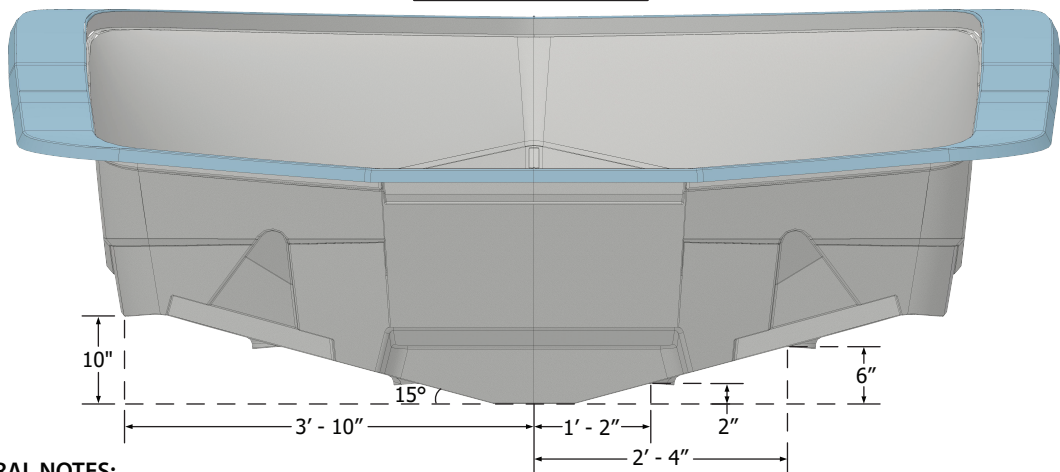

GENERAL NOTES:

1. MOLD FLANGES NOT COUNTED TOWARDS MEASUREMENTS.
2. ACTUAL AND PARTICULAR BOATS WILL VARY BASED ON ACTUAL AS-BUILT CONFIGURATION.
3. SHIPCHECK ALL DIMENSIONS PRIOR TO CONSTRUCTION OF BOATLIFT OR TRAILER.
4. ALWAYS SUPPORT BOAT ON STRINGERS AND BULKHEADS AS DEPICTED.
5. CREVALLE MAKES NO GUARANTEE OR WARRANTY, EXPRESSED OR IMPLIED, REGARDING ACCURACY OF THIS INFORMATION FOR A PARTICULAR BOAT. ALWAYS CHECK MEASUREMENTS ON ACTUAL BOAT.

DRAWN BSM	6/28/2023			
APPROVED NLE	7/11/2023			
REVISED		TITLE		
		BOAT DIMENSIONS		
CREVALLE BOATS 1520 INDUSTRIAL DR WILDWOOD, FLORIDA 34785 USA		SIZE D	MODEL B4 - 26HCO	REV 1
SCALE 1 / 25		SHEET 1 OF 2		